

MULTITEL MX200DS

NISSAN CABSTAR 35.11 / 35.13 MY06

D43637

Ente	Rev.	Descrizione	Data	Dis.	Contr.	Ap.AQ
MRK	0	EMISSIONE	08-10-09	P.F.		
INGOMBRO - SCHEDA 54/1 - Rev. 0 - 15/12/00						

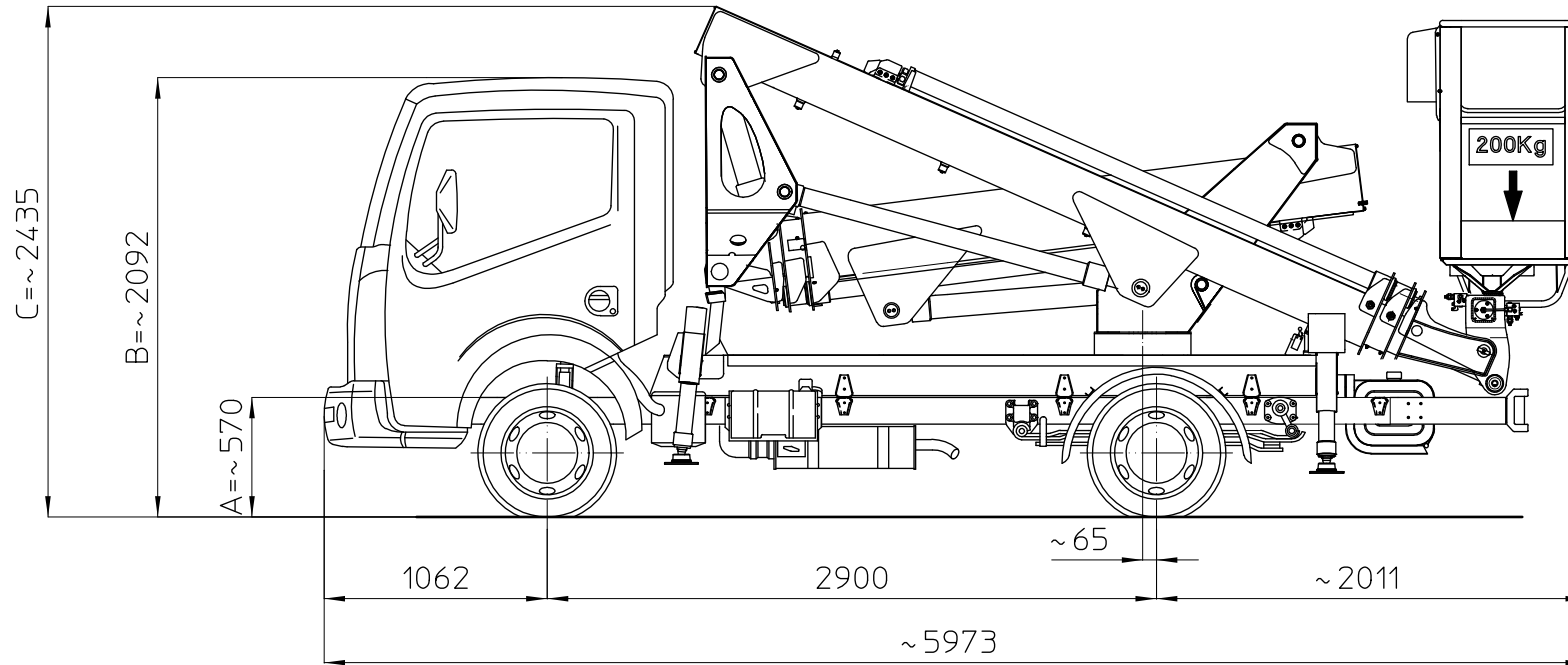

Le quote A-B sono relative alle dimensioni dell'autocarro, quindi devono essere verificate sullo stesso.
La quota C (altezza totale) e' subordinata alle quote A-B e non comprende eventuali parti flessibili.

Les cotes A-B sont relatives aux dimensions du porteur, donc elles doivent être vérifiées sur le porteur même.
La cote C (hauteur totale) est subordonnée aux cotes A-B est indiquée hors flexibles.

The dimensions A-B are related to the truck sizes, therefore they must be verified.
The dimension C (total height) is subject to A-B and does not include hoses.

Die Abmessungen A-B betreffen die Fahrzeugmasse, daher sollen sie geprüft werden.
Die Abmessung C (Gesamthöhe) hängt von A-B Abmessungen ab, die schläuche sind ausgeschlossen.

	TIPO DI STABILIZZAZIONE	PORTATA CESTELLO (kg)	
		200 kg	
DIAGRAMMI DI LAVORO	PIEDI IN SAGOMA	D43638	
	PIEDI PARZIALI		
	PIEDI ESTESI		
	SOTTOPONTE		
CARICO UTILE			
DIS. STABILIZZAZIONE		D43639	
AUTOCARRO	1°ASSE		2°ASSE
TARE A VUOTO	1170 kg		510 kg
MASSIMI AMMESSI	1750 kg		2200 kg
P.T.T.		3500 kg	
NOTE:			

MULTITEL

MX 200 DS

Ente	Rev.	Descrizione	Data	Dis.	Contr.	Ap.AQ
MRK	0	EMISSIONE	08-10-09	P.F.		
DIAGRAMMA - SCHEDA 54/2 - Rev. 0 - 15/12/00						

D43638

200kg

SBRACCIO DI LAVORO	8.8 m	±5%
WORKING OUTREACH	8.8 m	±5%
DEPORT DE TRAVAIL	8.8 m	±5%
SEITLICHE REICHWEITE	8.8 m	±5%

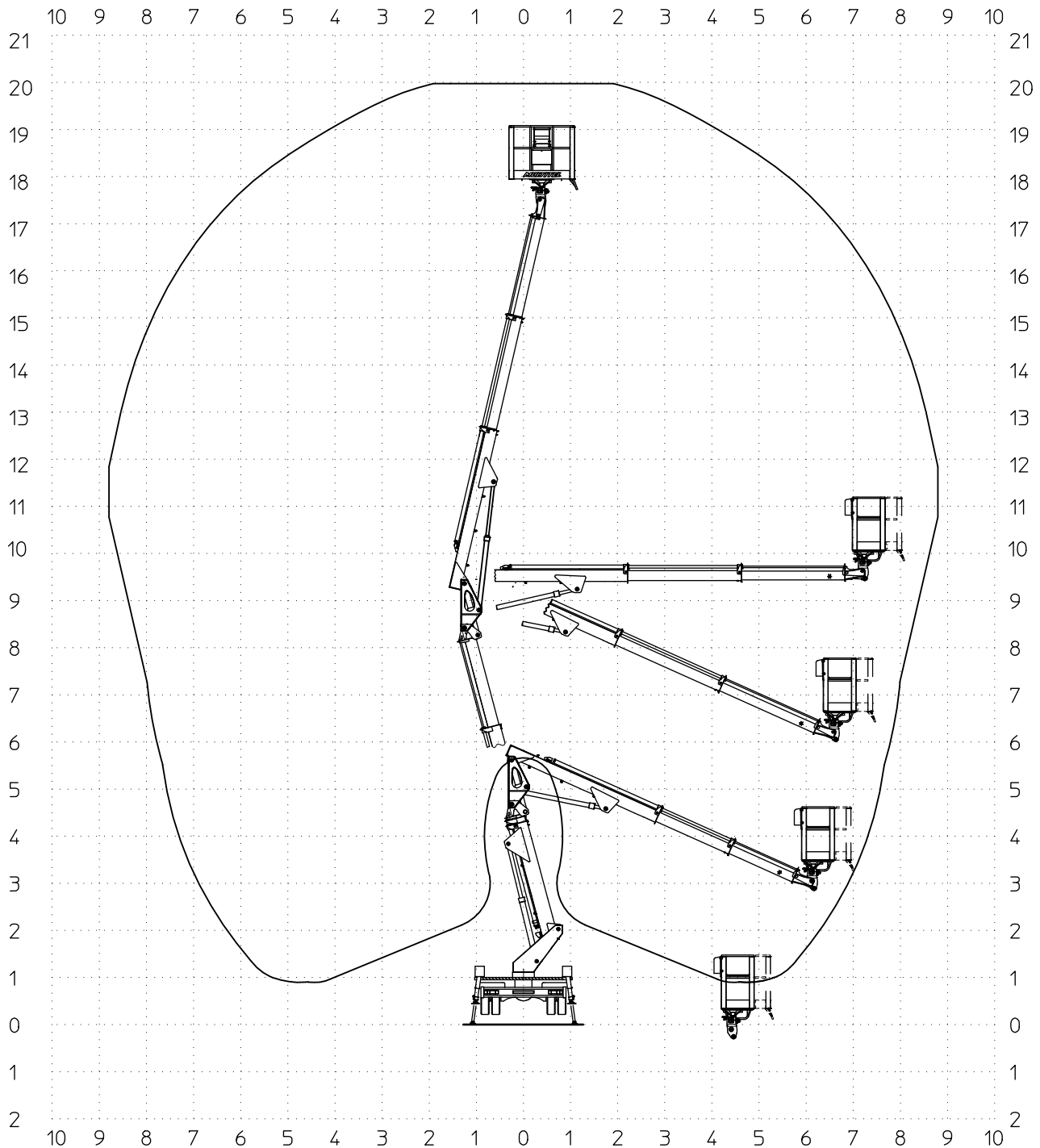

MULTITEL MX2000S

NISSAN CABSTAR 35.11 / 35.13 MY06

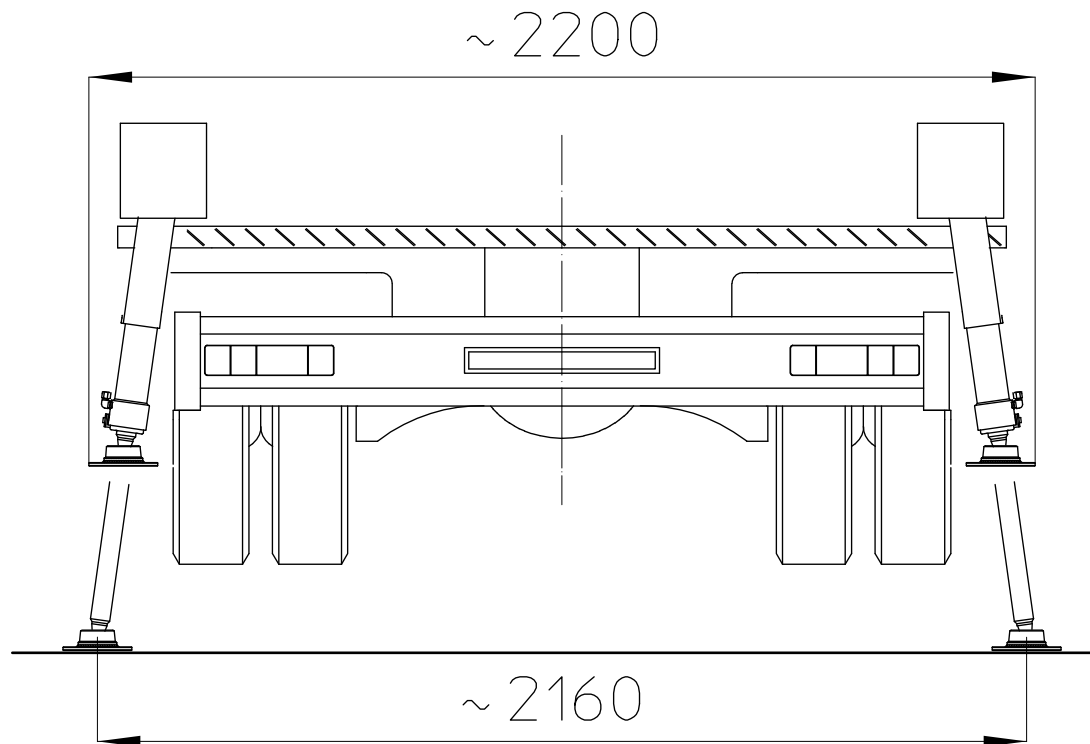

D43639

Ente	Rev.	Descrizione	Data	Dis.	Contr.	Ap.AQ
MRK	0	EMISSIONE	08-10-09	P.F.		
INGOMBRO - SCHEDA 54/1 - Rev. 0 - 15/12/00						